

AVIGILON
THE BEST EVIDENCE™

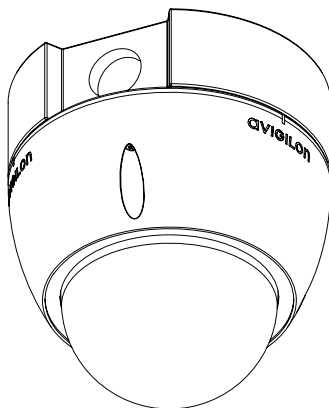

Operating and Installation Instructions

Avigilon High Definition IP Dome Camera Indoor/Outdoor Mounting Base DOME-OD-BASE

Avigilon Corporation
Vancouver
Canada

TEL 604.629.5182
FAX 604.629.5183

avigilon.com

Installation

Installation Steps

Follow these steps to install the indoor/outdoor mounting base. Details on how to complete each of these steps are in the following sections.

1. Check the package contents against the list below.
2. Mount the indoor/outdoor mounting base.
3. Mount the dome camera.

Package Contents

The package contains the following:

- Avigilon High Definition IP Dome Camera Indoor/Outdoor Mounting Base
- 3 Screws for Mounting Dome
- 4 Screws, Rubber Sealing Washers, and Anchors for Solid Walls
- 3/4" NPT Closure Plug
- Teflon Sealing Tape
- Drill Template

Mounting the Indoor/Outdoor Mounting Base

To mount the indoor/outdoor mounting base, complete the following steps:

1. Determine if the cables will enter through the side or rear 3/4" NPT conduit hole in the base and use the supplied closure plug to fill the unused conduit hole. When installing outdoors, wrap the supplied Teflon tape around the thread of the plug to create a water tight seal.
2. Attach a conduit connector to the 3/4" NPT conduit hole. When installing outdoors, ensure that the conduit fitting and conduit are for outdoor use and have a suitable IP rating for the environment they will be installed into. Install conduit and conduit fitting according to applicable instructions.
3. Using the drill template, drill four mounting holes in the ceiling/wall. When installing outdoors, the conduit hole must face downwards if the base is installed on a vertical surface.

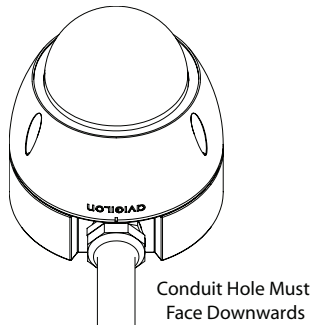

Figure: Base orientation when installed on a vertical surface

4. Mount the base on the ceiling/wall using the supplied screws and anchors. Use the supplied rubber washers to create a water tight seal between the screws and the base.

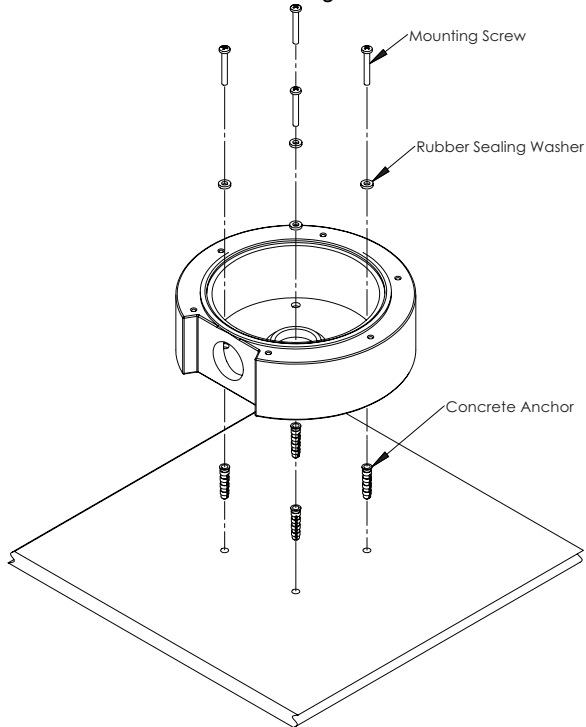

Figure: Indoor/Outdoor Mounting Base Installation



Caution

- If the Avigilon dome camera is not mounted according to the instructions, there may be problems with moisture which is not covered by warranty.
- Vandal resistant conduits should be used to protect the cables in order to comply with the vandal resistant design of the Avigilon dome camera.

Mounting the Dome Camera

To mount the dome camera, complete the following steps:

1. Drive the three supplied screws into the holes on the mounting base and leave 6 mm (1/4") between the screw head and the surface.
2. Pull the cables through the cable entry hole in the mounting base and the cable entry hole in the dome camera.
3. Place the dome base on the screws using the keyed mounting slots and rotate it clockwise.
4. Tighten the screws to hold the dome camera in place and to create a water tight seal between the dome and the mounting base.
5. Finish the installation of the dome camera according to the dome camera installation instructions.

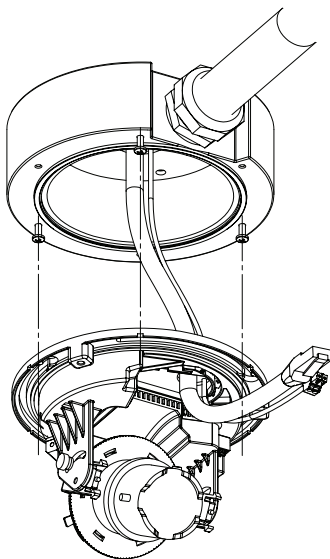

Figure: Dome Camera Installation

Limited Warranty & Technical Support

Avigilon warrants to the original consumer purchaser, that this product will be free of defects in material and workmanship for a period of 3 years from date of purchase. The manufacturer's liability hereunder is limited to replacement of the product, repair of the product or replacement of the product with repaired product at the discretion of the manufacturer. This warranty is void if the product has been damaged by accident, unreasonable use, neglect, tampering or other causes not arising from defects in material or workmanship. This warranty extends to the original consumer purchaser of the product only.

AVIGILON DISCLAIMS ALL OTHER WARRANTIES EXPRESSED OR IMPLIED INCLUDING, WITHOUT LIMITATION, ANY IMPLIED WARRANTIES OF MERCHANTABILITY OR FITNESS FOR A PARTICULAR PURPOSE, EXCEPT TO THE EXTENT THAT ANY WARRANTIES IMPLIED BY LAW CANNOT BE VALIDLY WAIVED.

No oral or written information, advice or representation provided by Avigilon, its distributors, dealers, agents or employees shall create another warranty or modify this warranty. This warranty states Avigilon's entire liability and your exclusive remedy against Avigilon for any failure of this product to operate properly.

In no event shall Avigilon be liable for any indirect, incidental, special, consequential, exemplary, or punitive damages whatsoever (including but not limited to, damages for loss of profits or confidential or other information, for business interruption, for personal injury, for loss of privacy, for failure to meet any duty including of good faith or of reasonable care, for negligence, and for any other pecuniary or other loss whatsoever) arising from the use of or inability to use the product, even if advised of the possibility of such damages. Since some jurisdictions do not allow the above limitation of liability, such limitation may not apply to you.

This Limited Warranty gives you specific legal rights and you may also have other rights which vary from jurisdiction to jurisdiction.

Warranty service and technical support can be obtained by contacting Avigilon Technical Support by phone at 1.888.281.5182 or via email at support@avigilon.com.

This page is intentionally left blank.

avigilon
THE BEST EVIDENCE™

©2010 Avigilon Corporation
V1.2