

Operating and Installation Instructions

Avigilon High Definition IP Dome Camera Indoor Electrical Box Mounting Plate DOME-INDE-PLT

Avigilon Corporation
Vancouver, BC
Canada, V6H 4E4

TEL 604.629.5182
FAX 604.629.5183

avigilon.com

Installation

Installation Steps

Follow these steps to install the indoor electrical box mounting plate. Details on how to complete each of these steps are in the following sections.

1. Check the package contents against the list below.
2. Mount the indoor electrical box mounting plate.
3. Mount the dome camera.

Package Contents

The package contains the following:

- Avigilon High Definition IP Dome Camera Indoor Electrical Box Mounting Plate
- 3 Screws for Mounting Dome
- 4 Screws and Anchors for Solid Walls
- Drill Template

Mounting the Indoor Electrical Box Mounting Plate

To mount the indoor electrical box mounting plate, complete the following steps:

1. Using the drill template, drill four mounting holes in the ceiling/wall. If mounting to an electrical box this step is not necessary. The mounting plate has hole patterns compatible with round, single gang and double gang electrical boxes.
2. Mount the base on the ceiling/wall using the supplied screws and anchors or using the screws supplied with the electrical box.

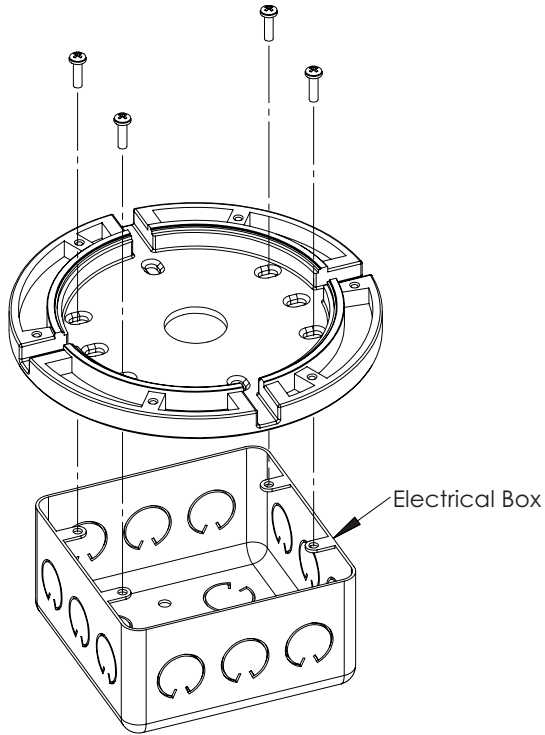

Figure: Indoor Electrical Box Mounting Plate Installation



Caution

- This mount is designed for indoor use only.

Mounting the Dome Camera

To mount the dome camera, complete the following steps:

1. Drive the three supplied screws into the holes on the mounting plate and leave 6 mm (1/4") between the screw head and the surface.
2. Pull the cables through the cable entry hole in the mounting plate and the cable entry hole in the dome camera.
3. Place the dome base on the screws using the keyed mounting slots and rotate it clockwise.
4. Tighten the screws to hold the dome camera in place.
5. Finish the installation of the dome camera according to the dome camera installation instructions.

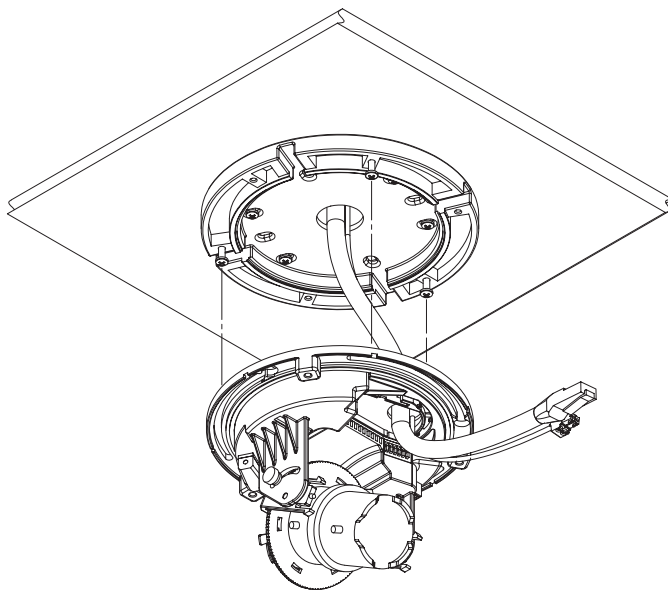

Figure: Dome Camera Installation

Limited Warranty & Technical Support

Avigilon warrants to the original consumer purchaser, that this product will be free of defects in material and workmanship for a period of 3 years from date of purchase. The manufacturer's liability hereunder is limited to replacement of the product, repair of the product or replacement of the product with repaired product at the discretion of the manufacturer. This warranty is void if the product has been damaged by accident, unreasonable use, neglect, tampering or other causes not arising from defects in material or workmanship. This warranty extends to the original consumer purchaser of the product only.

AVIGILON DISCLAIMS ALL OTHER WARRANTIES EXPRESSED OR IMPLIED INCLUDING, WITHOUT LIMITATION, ANY IMPLIED WARRANTIES OF MERCHANTABILITY OR FITNESS FOR A PARTICULAR PURPOSE, EXCEPT TO THE EXTENT THAT ANY WARRANTIES IMPLIED BY LAW CANNOT BE VALIDLY WAIVED.

No oral or written information, advice or representation provided by Avigilon, its distributors, dealers, agents or employees shall create another warranty or modify this warranty. This warranty states Avigilon's entire liability and your exclusive remedy against Avigilon for any failure of this product to operate properly.

In no event shall Avigilon be liable for any indirect, incidental, special, consequential, exemplary, or punitive damages whatsoever (including but not limited to, damages for loss of profits or confidential or other information, for business interruption, for personal injury, for loss of privacy, for failure to meet any duty including of good faith or of reasonable care, for negligence, and for any other pecuniary or other loss whatsoever) arising from the use of or inability to use the product, even if advised of the possibility of such damages. Since some jurisdictions do not allow the above limitation of liability, such limitation may not apply to you.

This Limited Warranty gives you specific legal rights and you may also have other rights which vary from jurisdiction to jurisdiction.

Warranty service and technical support can be obtained by contacting Avigilon Technical Support by phone at 1.888.281.5182 or via email at support@avigilon.com.

This page is intentionally left blank.

avigilon
THE BEST EVIDENCE™

©2010 Avigilon Corporation
V1.1