

# 8.0 Megapixel JPEG2000 Color 180° HD Panoramic Dome Camera

## Description

The Avigilon 8.0 megapixel JPEG2000 color 180° HD panoramic dome camera is a quad sensor progressive scan CMOS camera designed to cover a 180° field of view with a single wall mounted camera. It transmits images over 100BASE-TX using advanced JPEG2000 progressive compression technology to achieve the lowest network bandwidth and most efficient image storage in the industry while maintaining unsurpassed image quality.

The camera's advanced image acquisition system automatically adjusts the exposure time to ensure all available evidence is captured throughout the full range of day and night time scenes. The camera has mounting options for recessed in-ceiling mounting, mounting to an electrical box, and mounting in a sealed IP66-rated outdoor configuration.

The camera seamlessly integrates with Avigilon Control Center NVMS and High Definition NVRs using standard network equipment creating a network based surveillance solution with unmatched performance, ease of use, and ease of installation. Camera power is provided by either Power over Ethernet, 12 VDC, or 24 VAC

## Features

- 8.0 megapixel progressive scan CMOS sensor
- 180° field of view
- 7 images per second per sensor
- 70 dB true dynamic range
- 0.6 lux minimum illumination
- Lossless JPEG2000 compression
- Automatic exposure control
- Power over Ethernet, 24 VAC or 12 VDC power input
- External I/O interface and an audio input
- Vandal-resistant construction
- IP66 compliant with outdoor mount

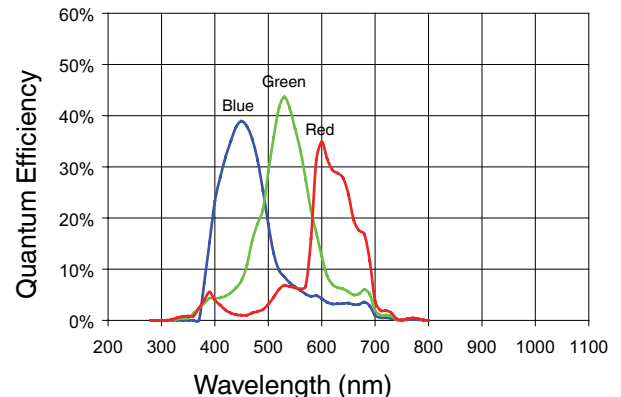

# Specifications

## Camera

Image Sensor	4 x 1/4" progressive scan CMOS
Active Pixels	1600 (H) x 1200 (V) per sensor
Imaging Area	3.5 mm (H) x 2.7 mm (V) per sensor 0.138" (H) x 0.106" (V)
Minimum Illumination	0.6 lux ( F2.0)
Dynamic Range	70 dB
Lens	F2.0 / 4.4 mm
Image Compression Method	JPEG2000
Image Rate	7 per sensor
Motion Detection	Selectable sensitivity and threshold
Electronic Shutter Control	Automatic, Manual (2 to 1/30000 sec)
Flicker Control	50 Hz, 60 Hz
White Balance	Automatic, Manual
Backlight Compensation	Automatic
Privacy Zones	Up to 4 zones per sensor
Audio Compression Method	G.711 PCM 8 khz
Audio Input	External 3.5 mm microphone input
External I/O Terminals	Alarm In, Alarm Out, RS-485

## Network

Network	100BASE-TX
Cabling Type	CAT5
Connector	RJ-45
Security	SSL
Protocol	UDP, TCP, SOAP, DHCP, Zeroconf

## Mechanical

Dimensions (ØxH)	150 mm x 120 mm 5.9" x 4.7"
Weight	0.91 kg (2.0 lbs) without lens
Dome Bubble	Polycarbonate, clear
Body	Aluminum
Housing	Surface mount, vandal resistant
Finish	Powder coat, cool gray 2

## Electrical

Power Source	VDC: 12-24 V VAC: 24 V PoE: IEEE802.3af Class 3 compliant
Power Consumption	9 W + 5 W with heater option
Power Connector	2-pin terminal block

## Environmental

Operating Temperature	-10 °C to +50 °C (14 °F to 122 °F) -30 °C to +50 °C (-22 °F to 122 °F) (with heater option)
Storage Temperature	-10 °C to +70 °C (14 °F to 158 °F)
Humidity	20 - 80% Relative humidity (non-condensing)

## Certifications

	UL 60950	CE
	CSA 60950	ROHS
	EN 60950-1	WEEE
Environmental	IK10 Impact Rating	Meets IP66 Weather Rating
Electromagnetic Emissions	FCC Part 15 Subpart B Class A IC ICES-003 Class A EN 55022 Class A EN 61000-6-3	EN 61000-3-2 EN 61000-3-3
Electromagnetic Immunity	EN 50130-4 EN 61000-4-2 EN 61000-4-3 EN 61000-4-4	EN 61000-4-5 EN 61000-4-6 EN 61000-4-11

## Ordering Information

8.0MP-HD-DOME-180	8.0 Megapixel JPEG2000 Color 180° HD Panoramic Dome Camera
8.0MP-HD-DOME-180-H	8.0 Megapixel JPEG2000 Color 180° HD Panoramic Dome Camera with Heater
DOME-INDE-PLT	Indoor Electrical Box Mounting Plate
DOME-IND-CEL	Indoor In-Ceiling Mount
DOME-OD-BASE	Indoor/Outdoor Mounting Base
DOME-OD-PEND	Indoor/Outdoor Pendant Mount
DOME-SMOKE	Replacement smoked transparent cover.

## Outline Dimensions

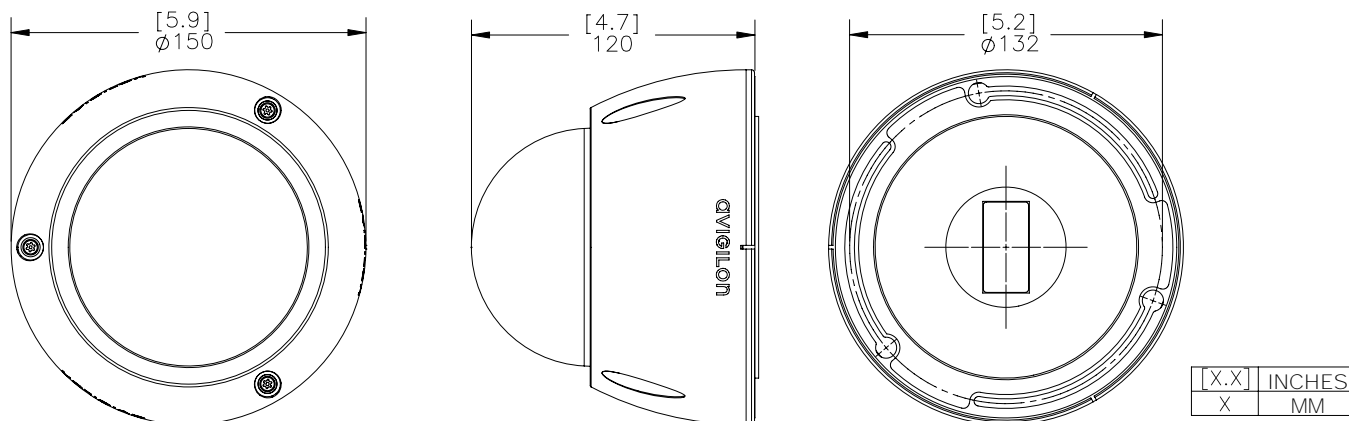

Specifications subject to change without notice. V1.1

©2011 Avigilon Corporation. All rights reserved.

Trademarks and registered trademarks are the property of their respective owners.